

PORTABLE SWITCH-MODE BATTERY CHARGERS

CDSP2 RANGE

24V TO 110V / 100A TO 20A for 3kW

24V TO 110V / 200A TO 40A for 6kW



The new CDSP range of chargers is perfectly adapted for battery maintenance.

- Portable
- Very light weight
- Easy installation and use
- High quality charging current for lead and NiCd batteries
- Very simple to use: programmable parameters of charging curve

Examples of use

Battery boost, emergency corrective maintenance

The CDSP Range can also be used as DC portable power supplies.

The charger is delivered with 2,5m input cable 3x2,5mm², and 3m output cable stored in a compartment at the back of the charger.

Protected by a ruggedized plastic case this equipment is compliant with the safety standard Class II. The wide track wheels and telescopic handle makes it easy for use both in the workshop and in field service.



STANDARD RANGE

OUTPUT VOLTAGE	MAXIMUM OUTPUT CURRENT	POWER	OUTPUT CABLES (3M)
24 Vdc	100 A	SIZE 1 3 kW	2 x 16 mm ²
48 Vdc	64 A		
72 Vdc	42 A		
110 Vcc	20 A		
24 Vdc	200 A	SIZE 2 6 kW	2 x 50 mm ²
48 Vdc	128 A		2 x 25 mm ²
72 Vdc	84 A		
110 Vdc	40 A		

CDSP2 – TECHNICAL SPECIFICATIONS

INPUT

- 230 Vac \pm 10 % single phases
- Frequency: 47 to 63 Hz
- Max current:
 - 16A model 3000W
 - 32A model 6000W

OUTPUT

- 24 Vdc, 48Vdc, 72Vdc, 96Vdc, 110Vdc
- Current electronically limited to nominal current
- Automatic charge functions
- Residual Ripple voltage <1%

USER INTERFACE

- ON / OFF Switch
- LED « mains presence »
- Digital voltmeter «output voltage »
- Digital ammeter «output current »
- 3 selectable charging curves (Pb, NiCd...)

PROTECTION

- Input fuse
- Protection against output overload
- Protection against short circuit
- Protection against output overvoltage
- Input/output galvanic isolation
- Thermal protection

STANDARDS

- EN61140 class II
- CE Certificate

PRESENTATION

- Portable plastic case with composite handle on the top
- Input cable = 2,5m, 3x2.5mm², plug supplied
- Output cable = 3m, 2x16 to 50mm², plug not supplied
- Storage of input and output cables in compartment at the back of the charger

MECHANICAL CHARACTERISTICS

- Size 1: 18 Kg (including cables)
- Size 2: 28 Kg (including cables)
- Protection: IP20

ENVIRONMENTAL SPECIFICATIONS

- Working temperature: -10°C to +45°C (with derating from 40°)
- Storage temperature: -20 à 70°C
- Humidity: 95 % without condensation

OPTIONS

- Programmation of up to 2 supplementary charging curves
- Input Voltage 115Vac
- Other output voltage
- Connection clips on output cable
- Battery temperature probe
- Pushbutton for emergency stop
- IP23
- Rucksack or trolley version
- High visibility cover (orange)

DIMENSIONAL CHARACTERISTICS

Size 1

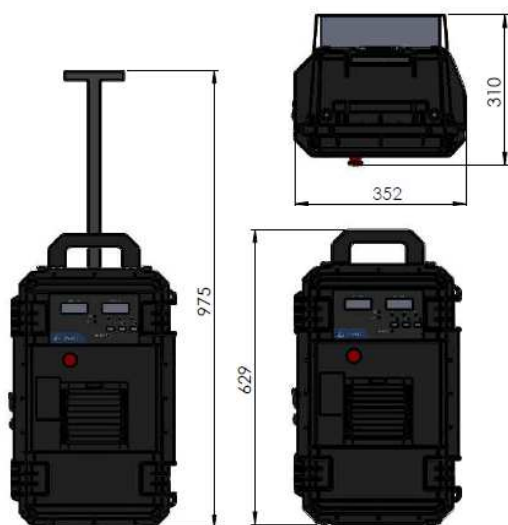

Size 2

